

Bill Bedford Models

LFF0200 NER E1 (J72) 0-6-0T Frames

Assembly suggestions

Frames

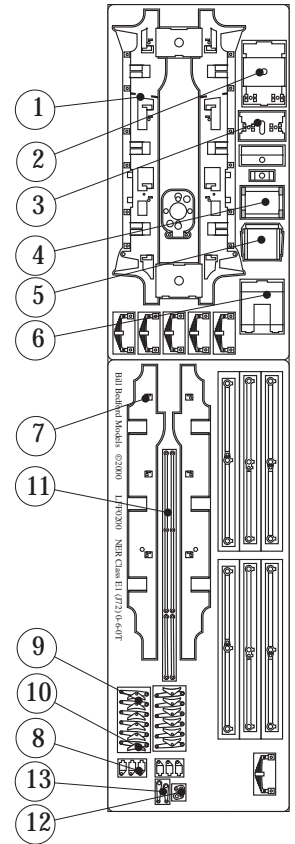
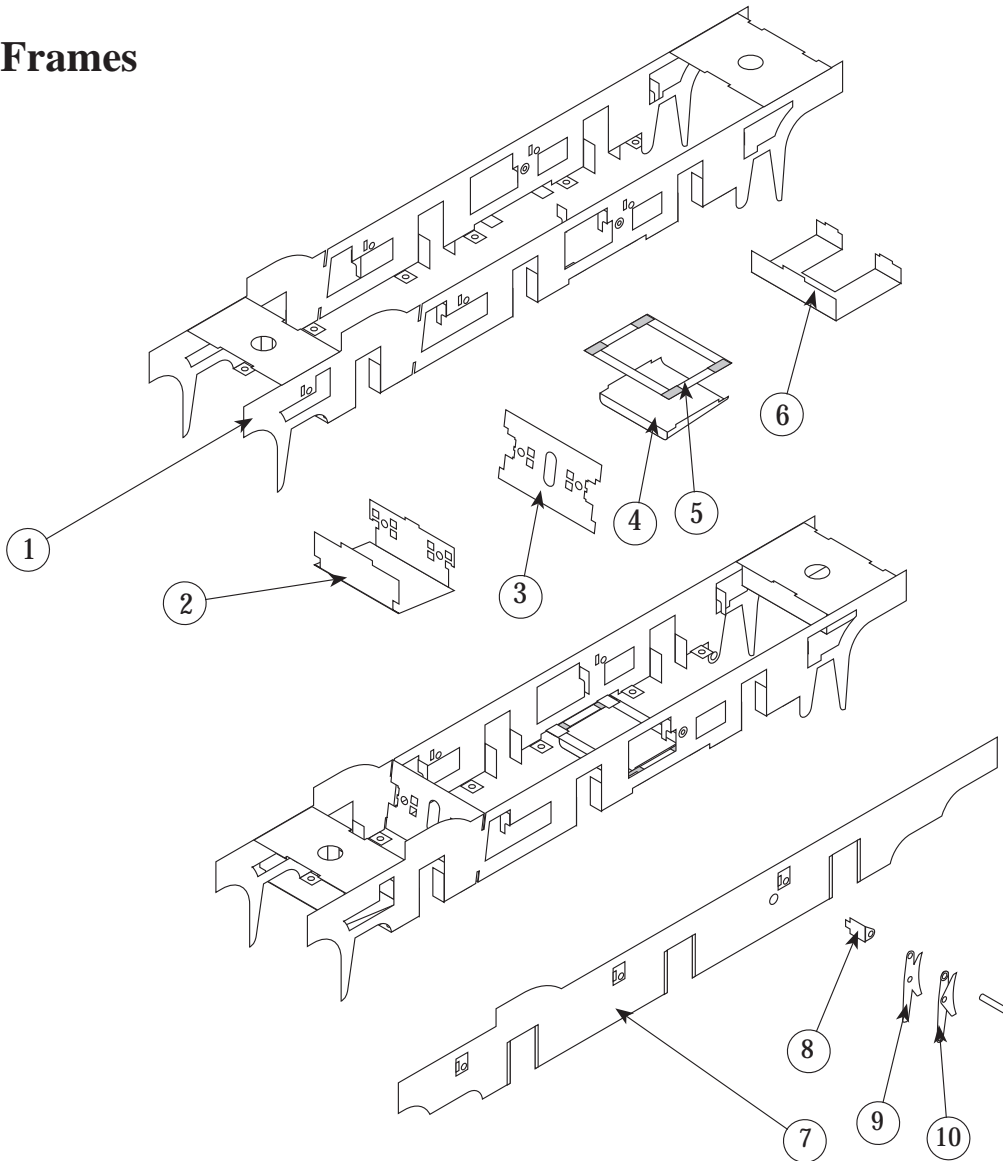

Brake Rigging

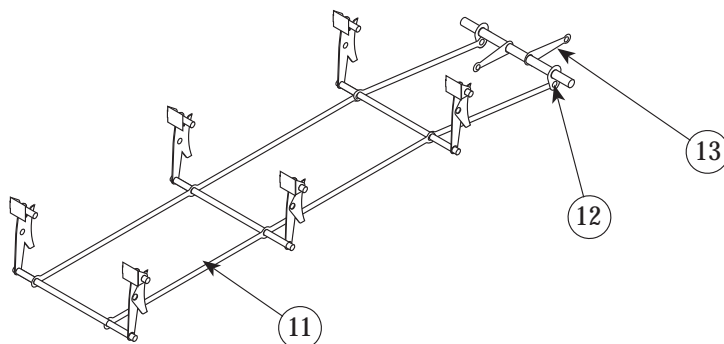

Suspension

Because of the way the frames have been drawn they should be self-jigging. It should therefore be impossible to introduce longitudinal errors in the placement of the hornguides.

The bearings are made to just rest on the spring wires, so any adjustments should be made by changing the gauge of the spring wire.

The hornguides are set by bending out each leaf, ensuring that they are as square as possible to the frame.

The hornguides should be bent out as close to square as possible. The bearings should be free to move vertically in the horn guides, and ideally with minimum fore and aft movement. It is probably more important and certainly easier to achieve, if the crankpins are a slop-free fit in the coupling rods. To test this, when the frames are complete and the wheels, rods and bearings assembled on the axles, hold one set of wheels and gently turn the other set relative to the first. There should be only a few degrees of rotation possible.

Test the wheelset assembly in the guides to check for any tight spots. Adjust the hornguides a little at a time if required.

Once free running is achieved, run solder into the horn guide fold lines.

Temporary keepers for the driving axles for use during construction can be made from soft copper wire.

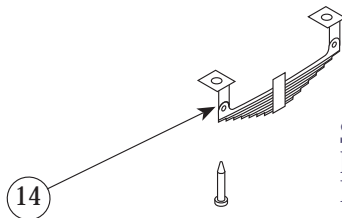
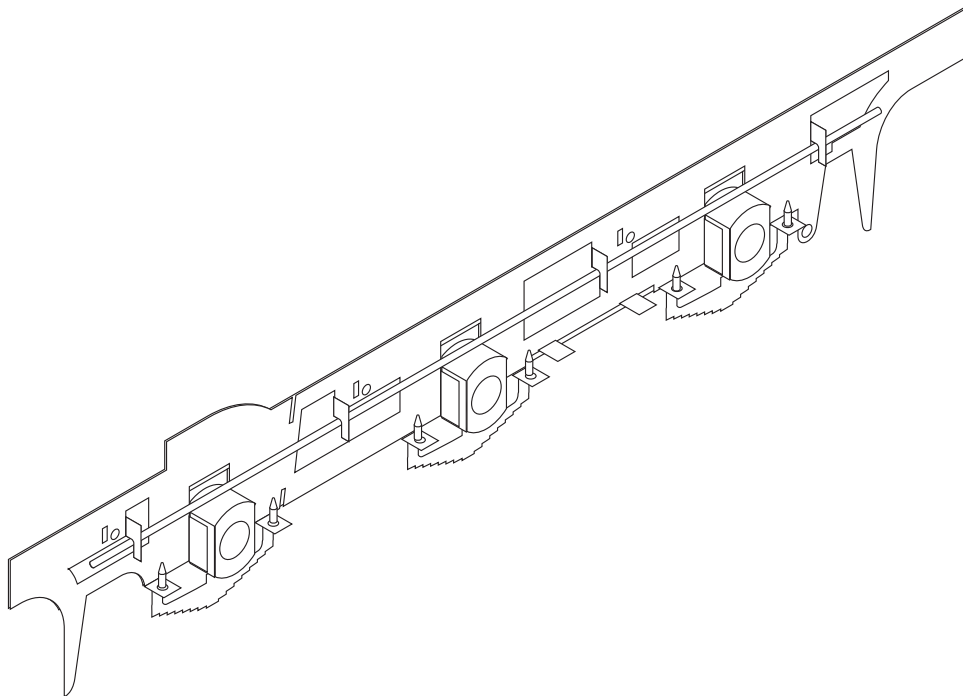

Spring etches form semi-permanent keepers. Pins soldered to spring will locate them in frames.

Coupling Rods

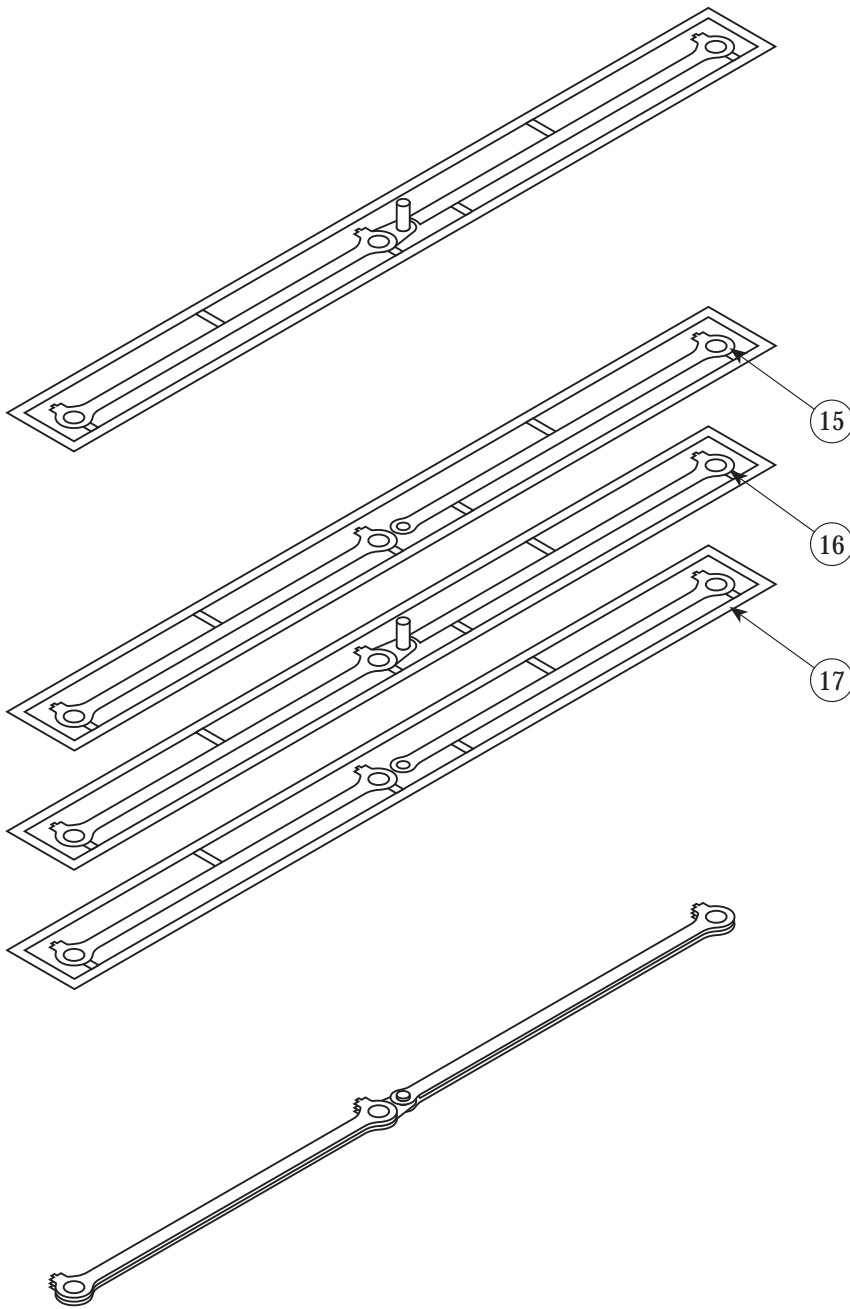

The coupling rods have been put into their own frames to facilitate their easy assembly.

Take a piece of hardwood, a offcut or sample of timber flooring is ideal, and drill a 1mm hole in it. Use a drill fixed in a stand or bench drill to ensure that the hole is square to the surface of the wood. The hole should be about 5mm deep.

Place a piece of 0.9mm brass wire into the hole and thread knuckle hole of the middle frame onto the wire. Solder the wire into the rod. Clean of any excess solder from the joint.

Assemble all three frames in order, and using the frames to align the rods solder them together ensuring that the knuckle pin is not soldered to the knuckle cheeks.

Remove the frame, trim off all the etching tabs, a piercing saw is recommended, and reduce the length of the knuckle pin

The crank pin holes can now be reamed to fit the crank pins.

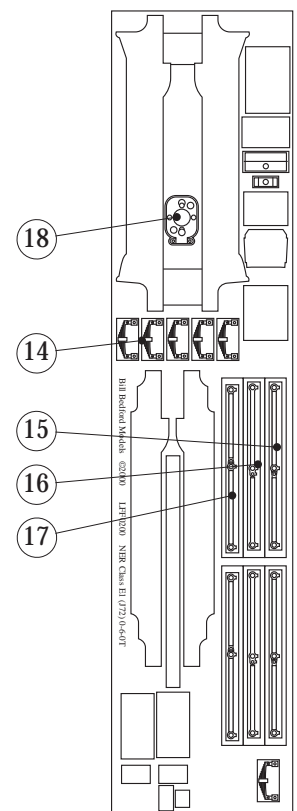

Finishing

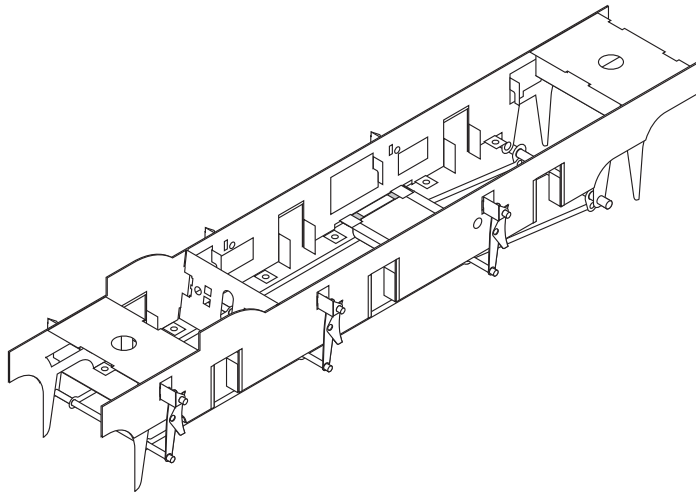

Motor Mount

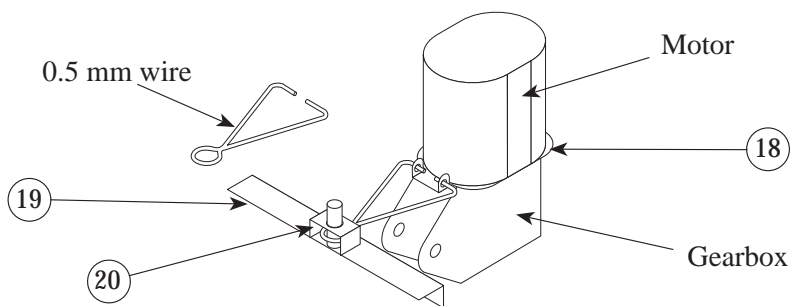

Suggestion for Motor mount / torque reaction arm
Not to scale

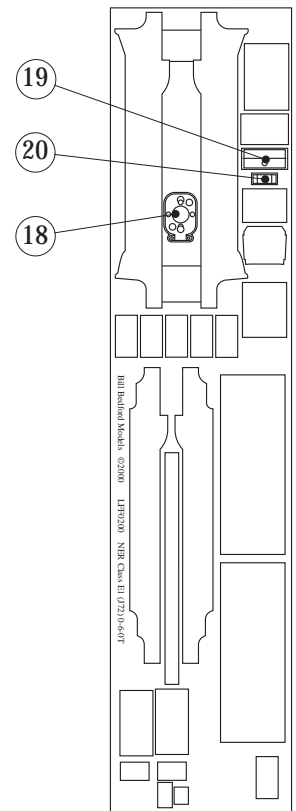

Errata

There is an error in the drawing for the bearing cut outs. The top edge of the cut out need to be raised by about 1mm and the fold side of the top edges of the 'barndoors' should be lowered by about 0.5 mm. This is best done before the 'barndoors' are folded. See sketch

The Frame overlay needs similar adjustments.

