

Bill Bedford Models

BUK850a, Trailer kit for Hornby and Lima DMUs Assembly Suggestions

This kit is a companion to the motorising kit BUK851. It features sprung primary and secondary suspension and provision for American pick-up giving smooth and trouble free operation.

Chassis spine

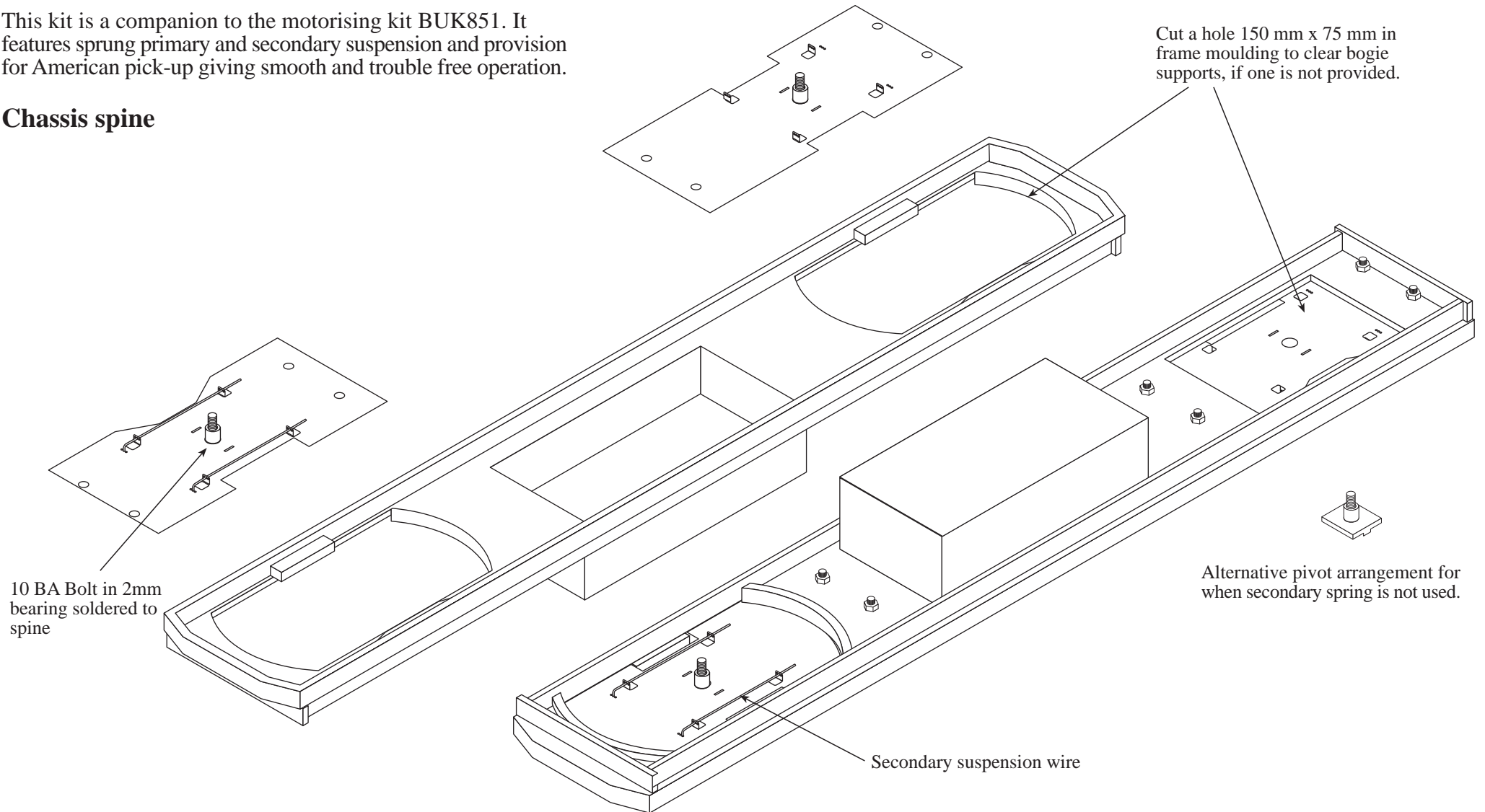

Bogies

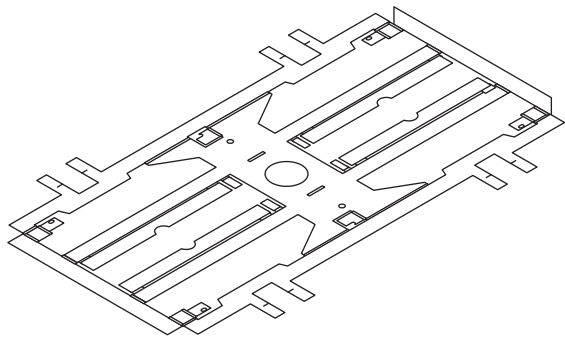

Reinforce fold lines with fine fillet of solder. Do not fill the slots at the ends of the longitudinals, these are needed for the brake assemblies

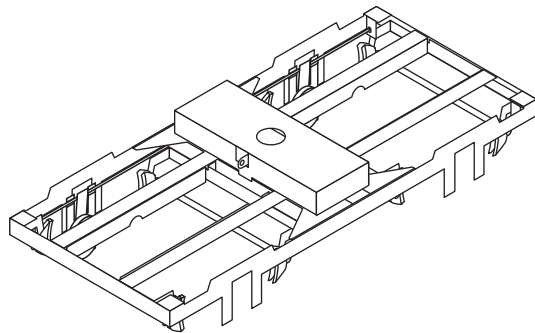
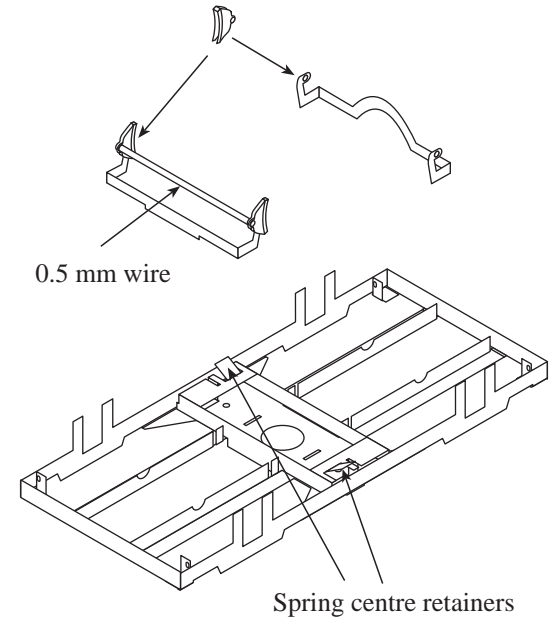
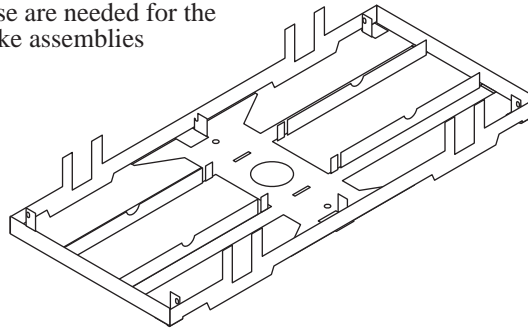

Fixing the spring to the carriers.

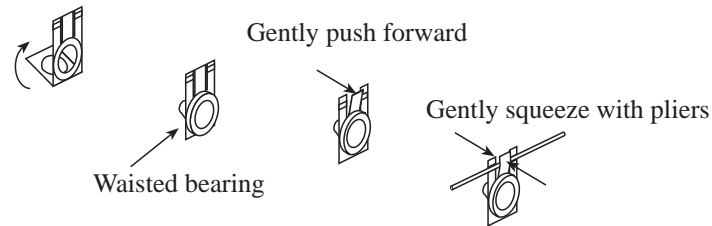

There is a manufacturing problem with axles and pinpoint bearings when used in bogie frames such as these. Because of the manufacturing tolerances of both the axles and bearings, there can be enough end float in the axles to affect the running. To overcome this a fret of thin washers are included. To use these the bearing **MUST NOT BE SOLDERED** into the carriers, instead they should be assembled with a low tack adhesive such as gum or paint. This way they can be easily disassembled and sufficient washers can be inserted to take up any end float.

The springs are pieces of straightened guitar string, obtainable at any music shop, or phosphor bronze wire to approximately the length of the side frame. The diameter required will vary according to the weight of the coach, for most, guitar strings of 11 or 12 thou will be about right.

The springs are threaded into the end carriers and must be long enough not to be able to withdraw from the end supports. Press the two centre spring retainers down against the side frames to finally retain the springs.

Finish in the normal way with wheels to suit and cosmetic sideframes of whitmetal, plastic or etched brass.

More information including building hints and tips can be found on the
CLAG website
<http://www.clag.org.uk>